



Field Installation and Usage Instructions

Part No. BLT-LP-VXX

Lap Belt Assembly

For All Model TMM Chairs

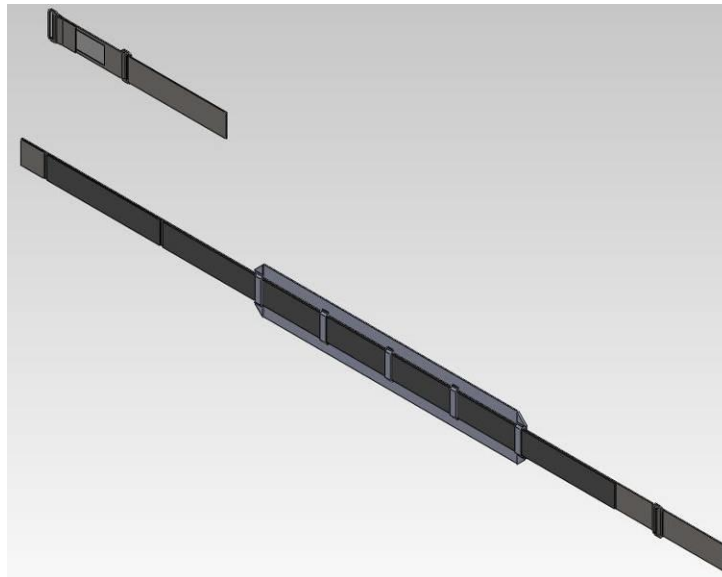

5516 S.W. 1st Lane – Ocala, FL 34474-9307
Phone: 1-800-237-3377 - Fax: 1-352-854-9544
www.transmotionmedical.com

Document No.: IM BLT-LP-VXX
Revision: D

TABLE OF CONTENTS

IMPORTANT NOTES ABOUT THIS MANUAL.....	3
SPECIAL NOTES - SIGNAL WORDS	3
TOOLS REQUIRED.....	4
PARTS INCLUDED FOR BLT-LP-VXX	4
PREPARING CHAIR FOR BELT INSTALLATION.....	4
INSTALLING BELT	5
FASTENING AND ADJUSTING BELT	7
CAUTIONARY USAGE INSTRUCTIONS	8
PREVENTATIVE MAINTENANCE	8
CLEANING INSTRUCTIONS	9
SERVICE INFORMATION.....	11

IMPORTANT NOTES ABOUT THIS MANUAL

This Field Installation and Usage Instruction manual is intended to assist you with installation of your TransMotion Medical Product. Carefully read this manual before using the equipment or doing service / maintenance on it. If you are unable to understand the WARNINGS, CAUTIONS, and instructions, contact TransMotion Medical Customer Service before attempting to operate or service the equipment. Otherwise, personal injury or property damage may result.

To ensure safe operation of this device, it is essential that methods and procedures be established for educating and training staff on the safe and effective operation of the product.

TransMotion Medical reserves the right to change specifications without notice.

The information contained in this document is subject to change without notice.

Specifications listed are nominal, and operation may vary slightly from unit to unit due to tolerance variations.

Figures contained within this document may not depict exactly the model you have. This document may cover many closely related models.

SPECIAL NOTES - SIGNAL WORDS

Signal words are used in this manual and apply to hazards which could result in injury or property damage. The following is a definition of those signal words as used in this document:



Indicates an imminently hazardous situation which, if not avoided, will result in death or serious injury.



Indicates a potentially hazardous situation which, if not avoided, could result in death or serious injury.



Indicates a potentially hazardous situation which, if not avoided, may result in minor or moderate injury. It may also be used to alert against unsafe practices or potential property damage hazards.



NOTICE

Provides important information, makes special instructions clearer, or provides service personnel information to make maintenance easier.

TOOLS REQUIRED

Tools are not required to install belts.

PARTS INCLUDED FOR BLT-LP-VXX

Verify that these parts have been received:

- Short Belt (with one adjustable double-D ring and one fixed double-D ring).
- Long Belt (with one adjustable double-D ring and Velcro® hook and loop sections).



For BLT-LP-V04 and BLT-LP-V06, an adjustable patient support (indicated by arrow in figure) is included, also.

If parts are missing, contact TMM Service Department toll-free at 1-800-237-3377.

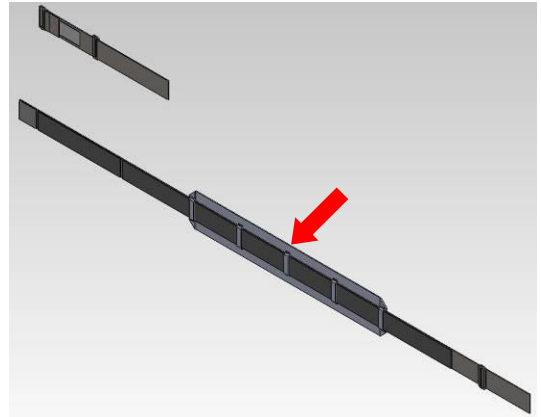

PREPARING CHAIR FOR BELT INSTALLATION

Position chair to allow easy access to two slots through back section.



Depending on chair model, there may be up to three pairs of slot locations for belt placement.

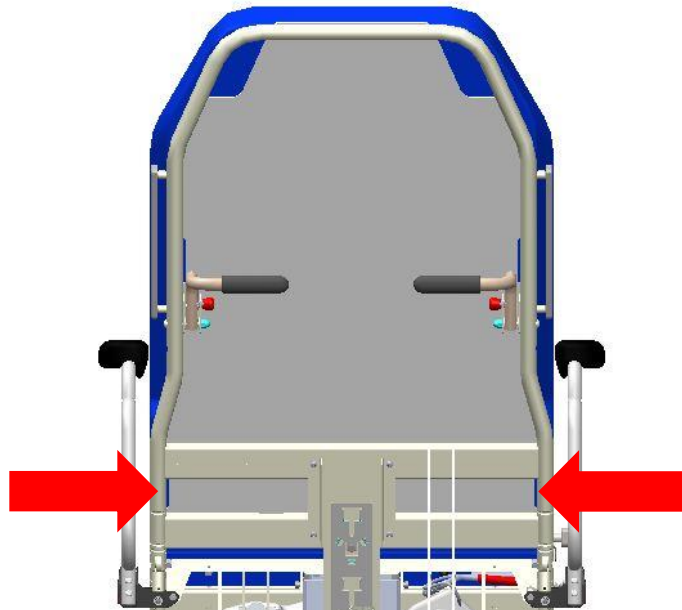

INSTALLING BELT

To install short belt:

- 1) Move adjustable double-D ring to about ten inches from plain end (i.e. no ring).

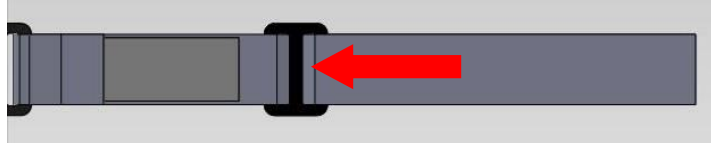

- 2) Feed belt from front of chair through slot of back frame and around tube.



For better appearance, tag should face patient.

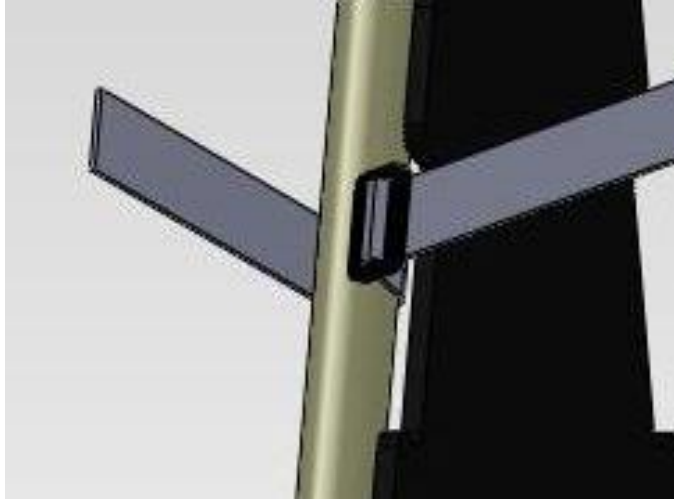

- 3) Feed belt (again) through double-D ring, and pull excess length through ring.

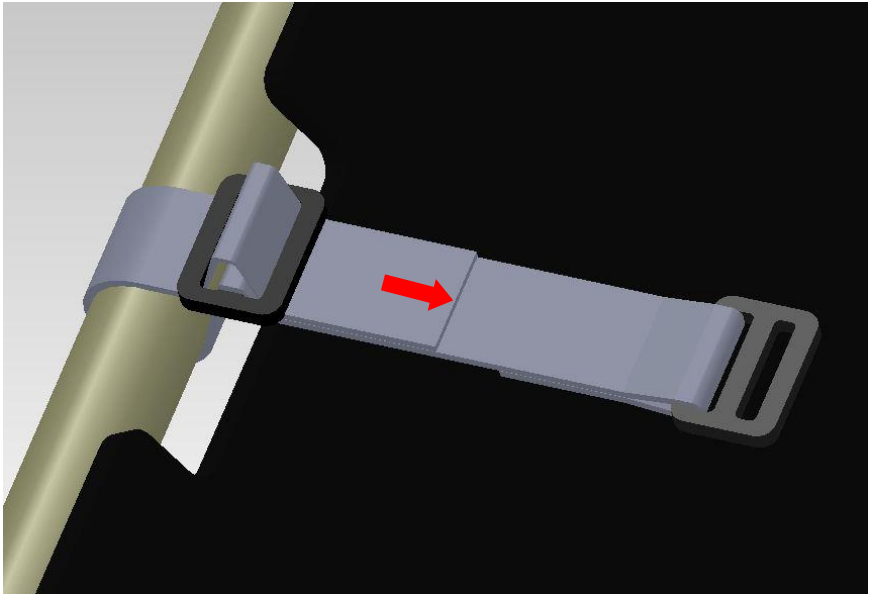

To install long belt:

- 1) Move adjustable double-D ring to about eight inches from plain end (i.e. no Velcro®).

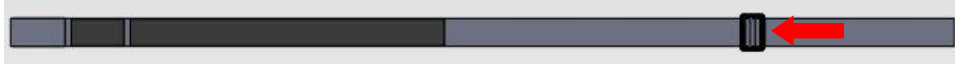

- 2) Feed belt from front of chair through other slot of back frame and around tube.



For proper use, Velcro® should face outward (away from patient).

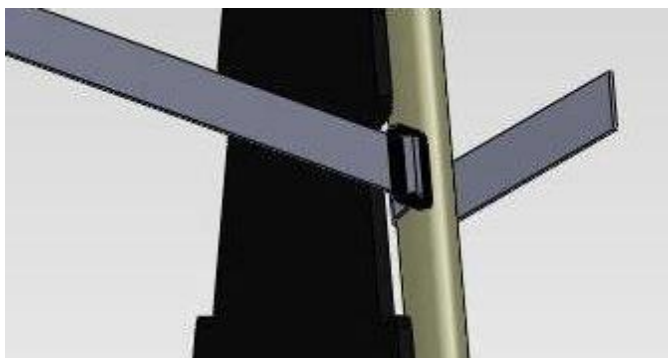

- 3) Feed belt (again) through double-D ring, and pull excess length through ring.

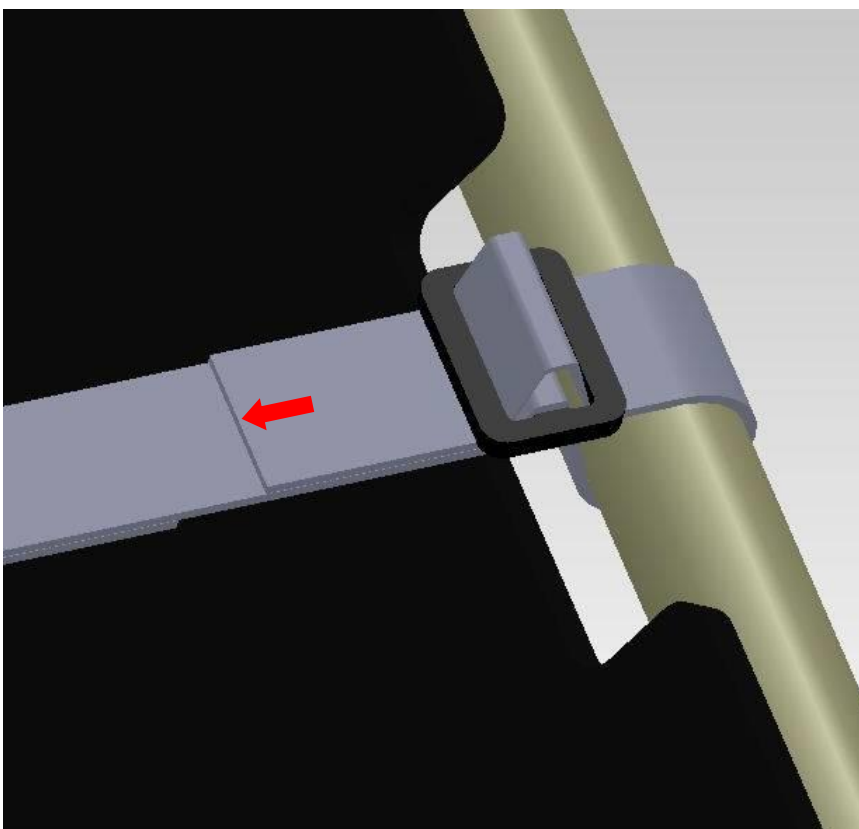

FASTENING AND ADJUSTING BELT

To fasten belt:

- 1) With patient in chair, place long belt around patient's lap / abdomen / chest, and feed Velcro® through fixed ring of short belt.

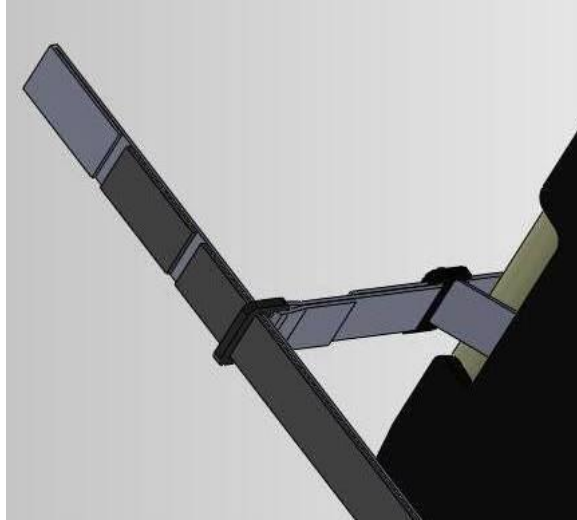

- 2) Pull excess length through fixed ring, and fold belt back to engage Velcro® hook (abrasive) and loop (soft) areas.



Ensure proper fit and patient's comfort while fastening belt.

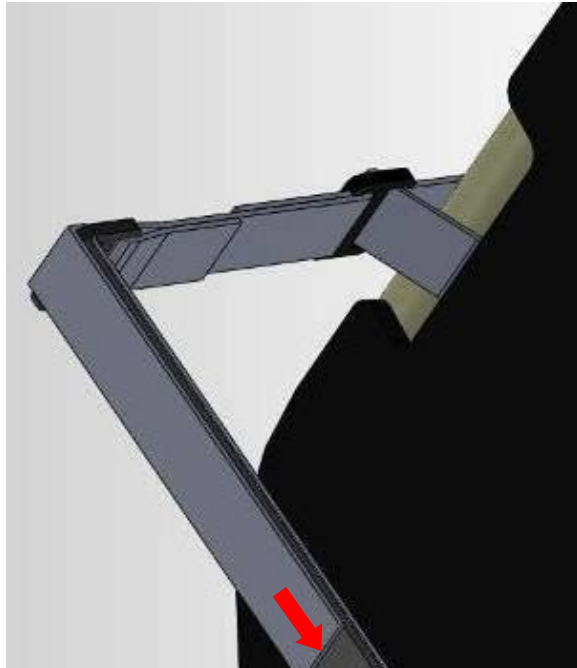

To adjust belt:

For patients with larger and smaller torsos, belt length may need to be adjusted to ensure engagement of Velcro®. Either belt can be adjusted by reversing installation process, moving adjustable double-D ring as needed, and then repeating installation.



WHEN ADJUSTING BELT LENGTH, ENSURE AT LEAST ONE INCH OF EXCESS BELT EXTENDS BEYOND DOUBLE-D RING TO PREVENT BELT FROM SLIPPING OUT OF DOUBLE-D RING.

CAUTIONARY USAGE INSTRUCTIONS

When using this accessory, please follow these cautionary usage instructions:

CAUTION

- TO PREVENT PERSONAL INJURY TO PATIENT AND MEDICAL STAFF, FOLLOW YOUR MEDICAL FACILITY'S PROTOCOL FOR SAFE PATIENT HANDLING.
- ENSURE BELT IS PROPERLY INSTALLED AND SECURELY FASTENED PRIOR TO TRANSPORTING PATIENT IN CHAIR TO PREVENT PERSONAL INJURY TO PATIENT.
- ENSURE BELTS ARE PROPERLY STOWED PRIOR TO PATIENT EGRESS TO PREVENT PATIENT TRIPPING.
- BELTS ARE INTENDED FOR PATIENT USE ONLY. DO NOT SECURE MEDICAL EQUIPMENT WITH BELTS.

PREVENTIVE MAINTENANCE

To ensure proper operation, this accessory should be inspected and maintained as described below.

COMPONENT	FREQUENCY	PROCEDURE	TOOL	COMMENT
Belt Straps	Prior to each use	<ul style="list-style-type: none"> • Inspect belt strap for tears and fraying. 	-	If tears or significant fraying, replace belt.
Fixed Double-D Ring	Prior to each use	<ul style="list-style-type: none"> • Inspect stitching near ring. • Ensure ring is not bent or deformed. 	-	If loose / missing stitching is found, or if ring is deformed / bent, replace belt.
Velcro	Weekly	<ul style="list-style-type: none"> • Inspect for excessive debris in "loop" area. • Inspect for wear in "hook" area. 	-	Over time Velcro will deteriorate due to fastening action. If belt is used frequently, annual replacement is recommended.

CLEANING INSTRUCTIONS

⚠ CAUTION STEAM AND/OR PRESSURE CLEANING CHAIR WILL VOID WARRANTY

COMPONENT	FREQUENCY	PROCEDURE	CLEANING AGENT *	COMMENT
All Rails and Painted Metal	As required/in accordance with facility policies	Wipe with damp cloth and allow to air dry	Facility approved detergents, disinfectants & water	Check for chipped paint/chrome
Base Cover	As required/in accordance with facility policies	Wipe with damp cloth and allow to air dry	Facility approved detergents, disinfectants & water	Check for peeling or missing labels
Actuators and Battery Pack	As required/in accordance with facility policies	Wipe with damp cloth and allow to air dry	Facility approved detergents, disinfectants & water	Clean exterior surfaces only with minimal water
Pendants	As required/in accordance with facility policies	Wipe with damp cloth and allow to air dry	Facility approved detergents, disinfectants & water	Clean exterior surfaces only with minimal water
All Other Surfaces	As required/in accordance with facility policies	Wipe with damp cloth and allow to air dry	Facility approved detergents, disinfectants & water	Check for damage
TransMotion Medical Accessories	As required/in accordance with facility policies	Wipe with damp cloth and allow to air dry	Facility approved detergents, disinfectants & water	Check for damage
3rd Party Accessories	As required/in accordance with facility policies	Consult manual provided by accessory manufacturer.		

* Use of Facility approved detergents and disinfectants must comply with the instructions provided by the manufacturer(s) of those products.

Upholstery Care & Cleaning Instructions

Proper care is essential in ensuring the durability and reliability of TransMotion Medical upholstery. In general, all products should be:

1. Cleaned
2. Disinfected (in accordance with facility policy)
3. Rinsed
4. Allowed to air dry

It is important to note that the terms “disinfecting” and “cleaning” should not be used interchangeably. Disinfectants alone will not provide adequate cleaning since they do not have the appropriate properties to cut grease or oil and remove grime, hair or skin oils. The appearance, feel and performance of your upholstery may diminish if not cleaned properly.

Cleaning:

Remove hair, grime and body oils. Your upholstery should be cleaned on a regular basis with a damp cloth soaked in a mild soap and water solution. Avoid harsh detergents or chemicals that could damage the finish of your product. If disinfecting with manufacturer approved chemicals or bleach, the upholstery **MUST** be wiped off using clean water on a damp cloth and allowed to air-dry as a final step. Failure to rinse upholstery with clean water can result in a build-up of residues that, over time, may lead to drying, cracking or other undesirable changes to appearance, feel and performance.

Retain all instructional tags for future use.

Contact the manufacturer of the fabric used in your upholstery for a current list of approved disinfectants. TransMotion Medical Customer Care can assist with identifying which upholstery was used with your Stretcher-Chair.

For customer supplied and non-standard materials, please refer to the individual manufacturer’s cleaning instructions.

SERVICE INFORMATION

Customer service and support are important aspects of each TransMotion Medical product.

Prior to contacting TransMotion Medical for assistance with your accessory, please **HAVE YOUR CHAIR'S SERIAL NUMBER HANDY.**

Contact TransMotion Medical Service at:

TransMotion Medical
ATTN: Customer Service
5516 S.W. 1st Lane – Ocala, FL 34474-9307
United States of America

Phone: 1-800-237-3377
1-352-854-2929

Fax: 1-352-854-9544



Manufacturer of Device:
TransMotion Medical
5516 S.W. 1st Lane
Ocala, FL 34474-9307
United States of America

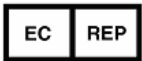

Authorized Representative in Europe:
Emergo Europe
Molenstraat 15
2513 BH, The Hague
The Netherlands

